

# ACOUSTIC SCREENS

## AREAS OF APPLICATION

### INDUSTRY - ENERGY PRODUCTION - TERTIARY - RAILWAY

- Optimal sound attenuation
- Customized sizing
- Optimized design
- Wide range of applications
- Robust steel construction
- Carefully crafted design
- Numerous customization options
- Guaranteed regulatory compliance
- Turnkey service

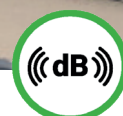

Certified performance



Turnkey offer



Optimized design



Custom dimensions

## PRODUCT DESCRIPTION

In a world increasingly marked by the growth of urban and industrial infrastructure, **noise management** has become a major priority to ensure people's comfort and well-being. BSE **acoustic screens** address this **issue** by offering an effective **solution** for **reducing noise pollution** in industrial applications, road and rail infrastructure, and residential environments.



Designed to **limit noise** propagation by acting as a physical barrier, acoustic screens offer optimal performance thanks to innovative materials and an optimized design specific to each project. In addition to their acoustic efficiency, these screens can be **designed** to blend harmoniously into their environment, combining **aesthetics** and **functionality**. The acoustic screens designed and manufactured by the Groupe Boët are constructed from acoustic panels and/or louvers that combine acoustic and airflow performance.

## SOLUTIONS ADAPTED TO A WIDE RANGE OF EQUIPMENT

Ventilation & air conditioning



Heavy industrial machinery



Fluid management industrial systems



Waste treatment equipment



Equipment for Energy production



Handling Equipment & material processing

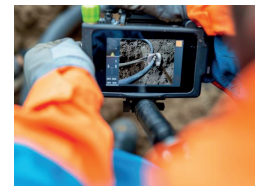

Industrial boilers & heating systems



Infrastructure and maintenance systems



## GRUPE BOËT EXPERTISE, A TURNKEY SERVICE:



At Boët StopSon, every project is unique and treated as such. We combine technical expertise, innovation, and rigor to design customized acoustic solutions that are perfectly tailored to our customers' needs.

Our R&D teams develop cutting-edge technologies to guarantee measurable performance, validated at every stage. This requirement is supported by structured project management, which ensures that deadlines, budgets, and performance commitments are met.

From design to on-site installation, we support our customers with a constant focus on for quality, efficiency, and results.



Each solution is designed to offer the best balance between performance, quality, and cost. This approach is part of a value engineering process: rethinking every component and every step to maximize efficiency while optimizing the resources used. Our human scale is a real lever for responsiveness. It allows us to quickly adapt our solutions to the constraints of each project and maintain a high level of flexibility in execution. Thanks to our expertise across the entire value chain, from design to on-site installation. This comprehensive integration guarantees our customers a single point of contact, smooth coordination, and commitments that are kept.



In a spirit of constant progress, the Groupe boët places continuous improvement at the heart of its strategy. By listening to the market, our customers, and our partners, we are developing our products, services, and methods to meet the changing requirements of our sector. This approach enables us to anticipate needs, enhance the quality of our offerings, and maintain a high level of performance throughout the value chain.

## HOW AN ACOUSTIC SCREEN WORKS:

The screen effect interrupts the direct path of sound waves emitted by sources. It creates a shadow zone to protect the receiver. The wave emitted by the source breaks down on contact with the screen as follows:

### 1 - Transmitted wave:

The wave that passes through the material without being absorbed or reflected. This wave can continue to propagate to the other side of the screen, but its energy is often reduced. The reduction in sound transmission in dB is characterized by the  $R_w$ , which varies from 34 to 36 dB for our BSP acoustic panels.

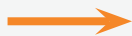

### 2 - Reflected wave:

The wave can bounce off certain materials. Boët acoustic panels have 100% absorption thanks to their perforated sheet metal, which allows sound to pass through to the mineral wool.



### 3 - Absorbed wave:

The wave vibrates the materials inside the walls, transforming the sound into heat. Boët's BSP panels absorb nearly 100% of sound waves. The absorption of a material is characterized by the  $\alpha_w$  coefficient (called Alpha Sabine), which ranges from 0 to 1, with 1 being the maximum absorption.

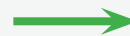

### 4 - Diffracted wave:

When a sound wave encounters an obstacle, some of its energy is deflected around the obstacle, creating a new wave that propagates in different directions. Diffraction can reduce the effectiveness of the acoustic screen if it is not properly taken into account in the design.

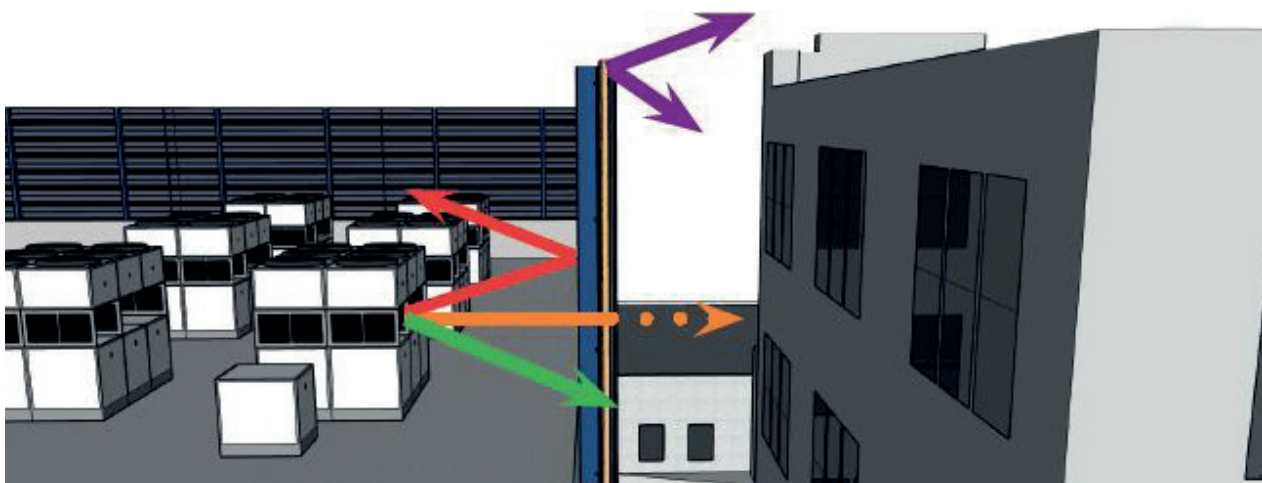

# OUR TURNKEY SOLUTION

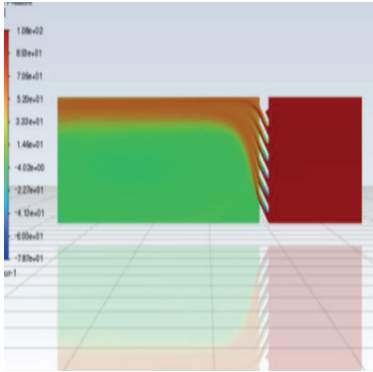

## 1 ACOUSTIC DIMENSIONING

We analyze specific sound attenuation requirements in accordance with ISO 9613-2:2024. This approach includes a site survey with measurements, modeling, and acoustic simulations to guarantee the performance of the screens. The solutions are tailored to the noise sources, space, and environmental constraints, while complying with regulatory requirements.

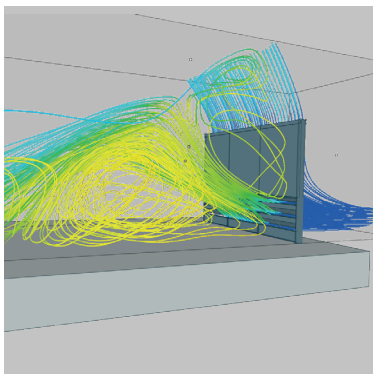

## 2 AERODYNAMIC DESIGN

The integration of aeroacoustic phenomena is essential to optimize equipment performance while meeting acoustic requirements. Our engineers use advanced tools such as Ansys to balance noise attenuation and pressure drop, ensuring optimal machine operation.

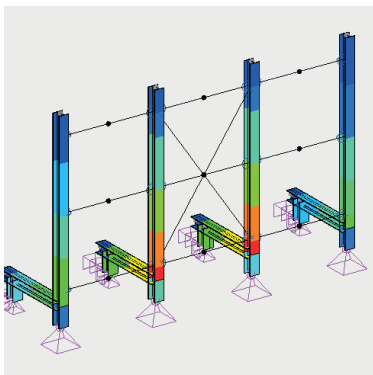

## 3 MECHANICAL DESIGN

We perform precise structural calculations in accordance with EUROCODE standards to ensure the stability, strength, and durability of the structures supporting the acoustic screens. Our experts take into account static and dynamic loads, seismic stresses, wind and the environment, thus guaranteeing the safety of installations throughout their service life.

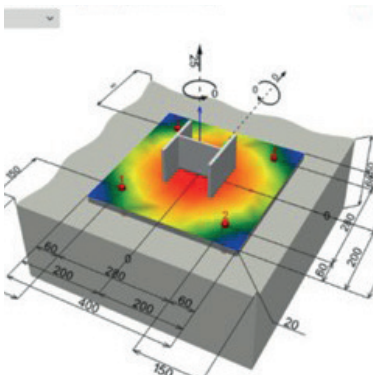

## 4 CIVIL ENGINEERING DESIGN

Our teams design and optimize the necessary foundations, such as concrete pedestals or sleepers, taking into account the characteristics of the terrain, the nature of the soil, and the loads to be supported. This crucial step ensures that the acoustic screens are built on solid foundations, tailored to the specific characteristics of each site, in order to prevent any movement or structural failure.

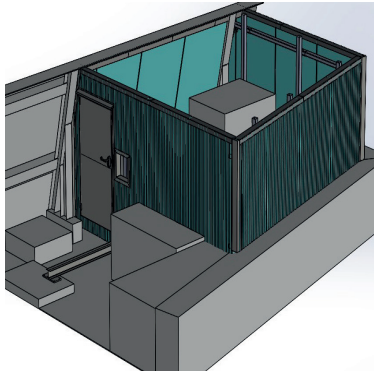

5

## STUDIES & DESIGN

We draw up detailed master plans, taking into account the environmental characteristics and specific features of the project. These technical documents include working drawings, layout plans, and details on the integration of components, ensuring perfect consistency throughout the project, from design to installation. This methodical approach facilitates efficient manufacturing and trouble-free installation.



6

## MATERIAL MANUFACTURING

All components required for the construction of acoustic screens, including primary and secondary frames, acoustic panels, acoustic grilles and doors, joint and finishing profiles, as well as anchors and fasteners, are manufactured or sourced by Boet StopSon. This manufacturing expertise guarantees perfect component compatibility, strict quality control, and flexibility to meet specific project requirements specific project requirements.



7

## CONSTRUCTION MONITORING & ASSEMBLY

We provide rigorous monitoring throughout the work, with expert supervision to ensure the quality and compliance of the installations. Our assembly team assembles the components with precision and efficiency, meeting deadlines and the highest safety and quality standards. This comprehensive management enables us to deliver optimized solutions tailored to the requirements of each customer and project.



# ACOUSTIC & AIRFLOW PERFORMANCE



Acoustic grilles are essential elements for ensuring optimal acoustic performance while providing adequate ventilation and guaranteeing the proper functioning of the technical equipment being treated.

For each project, Boet StopSon can provide detailed acoustic and airflow calculation notes justifying the performance of the technical solutions proposed.

These documents rigorously demonstrate the effectiveness of our devices in terms of noise reduction and air circulation.

The precise acoustic/airflow performance of our acoustic panels and grilles is listed in the dedicated technical data sheets. These performance levels are all obtained through laboratory measurements/tests, documented by test reports that comply with current regulations

The metal acoustic panels used in the construction of BSP screens offer an effective solution thanks to their dual function of sound insulation and absorption.

In terms of insulation, they block the transmission of noise from one space to another thanks to their metal structure and insulating layers. For absorption, their perforated surface and absorbent internal material reduce reverberation and echo, thereby improving sound quality and acoustic comfort.

Our screens can also be constructed (in part or in whole) from acoustic ventilation grilles

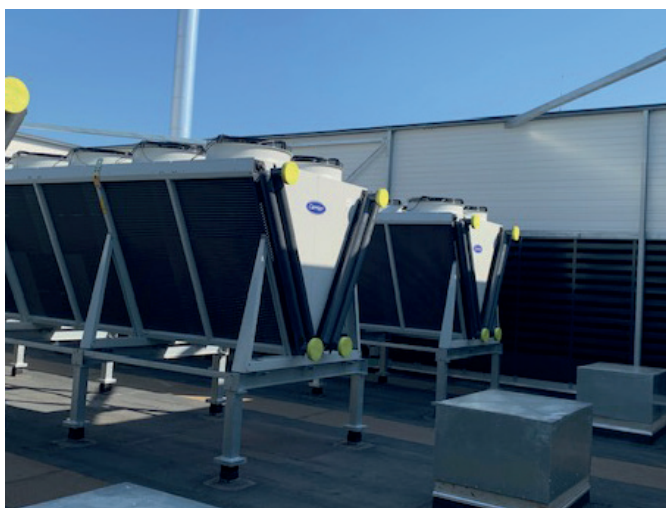
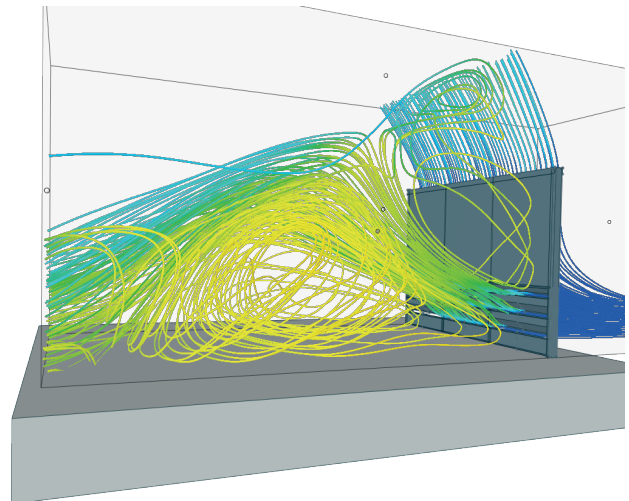

Acoustic calculation notes guarantee that our solutions meet acoustic performance objectives, taking into account the specific characteristics of the site, the sound sources to be attenuated, and regulatory requirements.

The airflow calculation notes ensure that airflow is properly managed without compromising acoustic performance and that our devices integrate optimally into their technical and operational environment.

This approach, based on rigorous analysis and data, guarantees our customers reliable solutions that are tailored to their specific needs and comply with current standards.

# THE DIFFERENT TYPES OF SCREENS

## > CHOICE OF MOUNTING METHOD

---

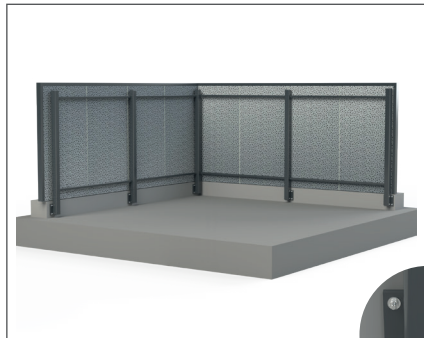

Longitudinal or acrotelial with English-style support

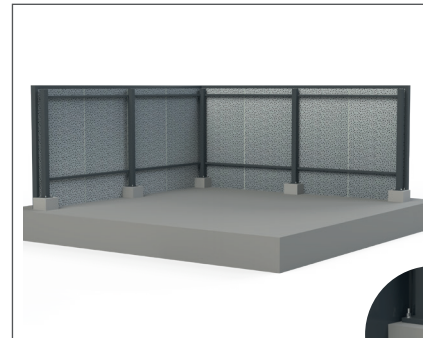
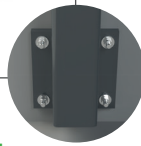

Concrete pedestals

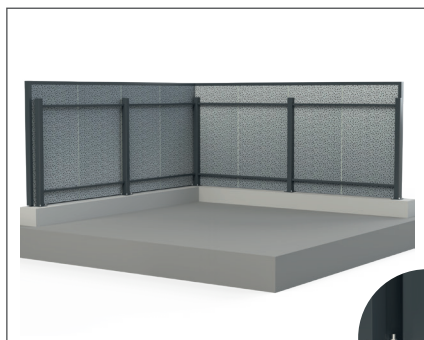
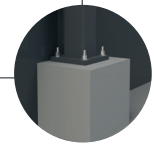

Longitudinal or acrotelial with French support

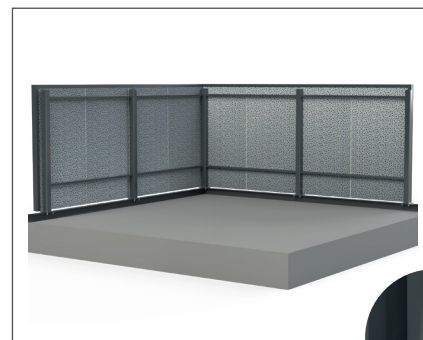

Metal frame

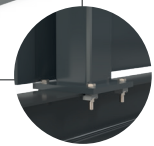

## > CHOICE OF TREATMENT TYPE

---

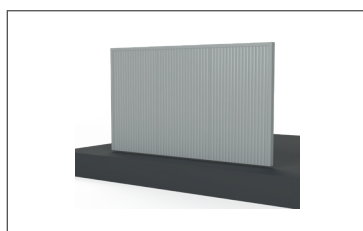

In panels

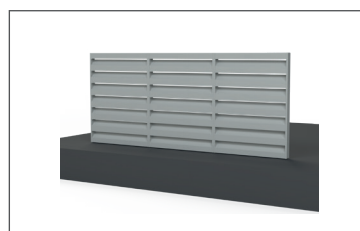

In louvers

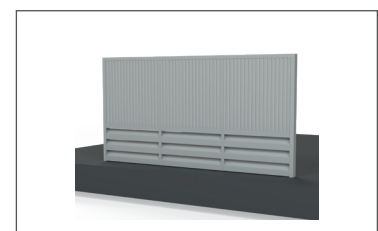

Mixed panels & louvers

## > CHOICE OF FRAMEWORK

---

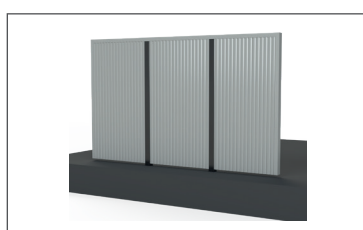

Visible from the outside

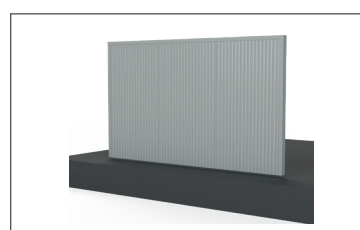

Not visible from the outside

## OPTIONS/SPECIFIC APPLICATIONS:

To meet your specific applications, our screens can incorporate:



### DOORS AND HATCHES

The integration of doors and hatches into acoustic screens allows easy access to protected equipment for maintenance, repairs, or inspection. These openings are designed to maintain the acoustic efficiency of the screen when closed, ensuring optimal noise insulation.



### VENTILATION SILENCERS

Ventilation silencers are used to control and reduce noise from ventilation systems. They maintain optimal airflow while reducing associated noise pollution, making acoustic screens more effective in environments requiring continuous ventilation.



### EXPANSION SYSTEMS

These devices help manage the effects of thermal or mechanical expansion of structures, preventing deformation or breakage due to temperature variations or structural movements. They guarantee the stability and longevity of acoustic screens, particularly in environments exposed to climatic variations.



### WHEELS/CASTORS (FOR MOBILE SOLUTIONS)

For mobile solutions, acoustic screens can be equipped with wheels or casters, allowing for quick and easy movement as needed. This option is particularly useful for temporary sites or installations requiring frequent reconfiguration.



### GLASS

Acoustic screens can be fitted with special glazing that combines transparency and acoustic performance. These glazing solutions maintain visibility while providing effective sound attenuation, making them ideal for environments requiring visual monitoring or natural light.



### CABLE, DUCT, AND PIPE PASS-THROUGHS

Specific passages can be integrated into the screens to allow electrical cables, ventilation ducts or pipes to pass through. These passages are designed to minimize sound leakage and ensure a perfect seal.



### DECORATIVE CLADDING SOLUTIONS

Decorative cladding solutions enhance the aesthetic appeal of acoustic screens, offering custom finishes that blend harmoniously with their surroundings. Cladding can be designed using a variety of materials, including patterns or textures, to meet architectural or landscaping requirements.



### GRATING

For access to technical equipment, grating floors can be integrated. Robust and secure, they ensure stable walking, promoting ventilation and drainage. Their open design limits dirt accumulation, simplifying maintenance. Adaptable, they offer a durable solution for HVAC equipment maintenance.

## THEY TRUST US

		<b>LIEBHERR</b>
		
		
	<b>ALSTOM</b>	
		<b>CATERPILLAR</b>

## OTHER PRODUCTS IN OUR RANGE

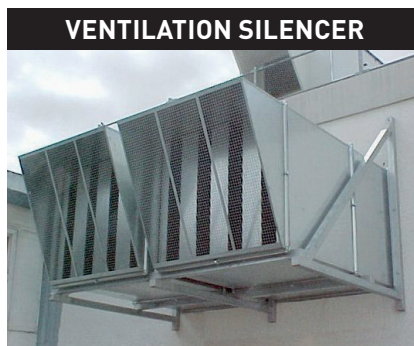

**GROUPE BOËT**

23 Rue d'Amsterdam - 59200 Tourcoing - FRANCE  
T: +33 (0)3 20 05 88 88 - [www.groupe-boet.com](http://www.groupe-boet.com)